



Rockford Sanitary Systems, Inc.

ROCKFORD, IL 61125-0963

(815) 229-5077 - (800) 747-5077 - FAX (815) 229-5108

WEB SITE-www.rkfdseparators.com E MAIL-rssem@inwave.com

MODEL NO. GFE-1820-M

GREASE SEPARATOR

DRAWN BY

QUOTE #

JOB NAME

W.R.W.

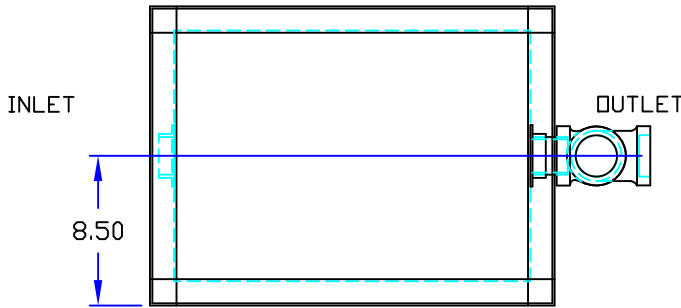

OPTIONAL FEATURES (ADDITIONAL COST)

- ANCHOR FLANGE
- CLAMP RING
- RECESSED LIFT HANDLES IN COVERS
- EPOXY COATING
- ANODES
- REINFORCED COVER
- ALUMINUM COVER
- STAINLESS STEEL CONSTRUCTION
- SEDIMENT BASKET
- FILTER MEDIA
- INTEGRAL EXTENSION 12.00 INCHES
- ALTERNATE VENT TAPPING SIZE _____ INCHES
- ALTERNATE INLET & OUTLET SIZE _____ INCHES
- CAST IRON OUTLET FITTINGS
- PVC OUTLET FITTINGS

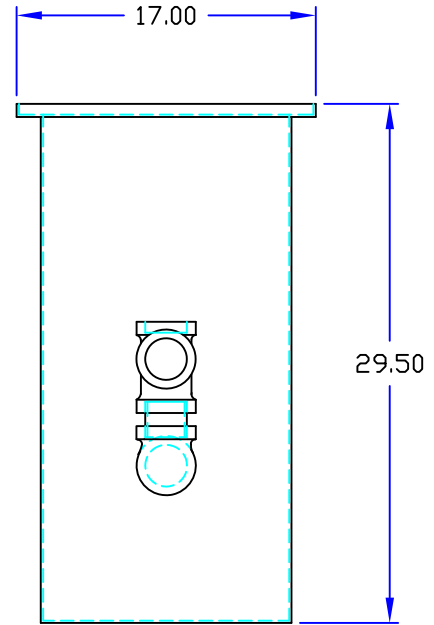
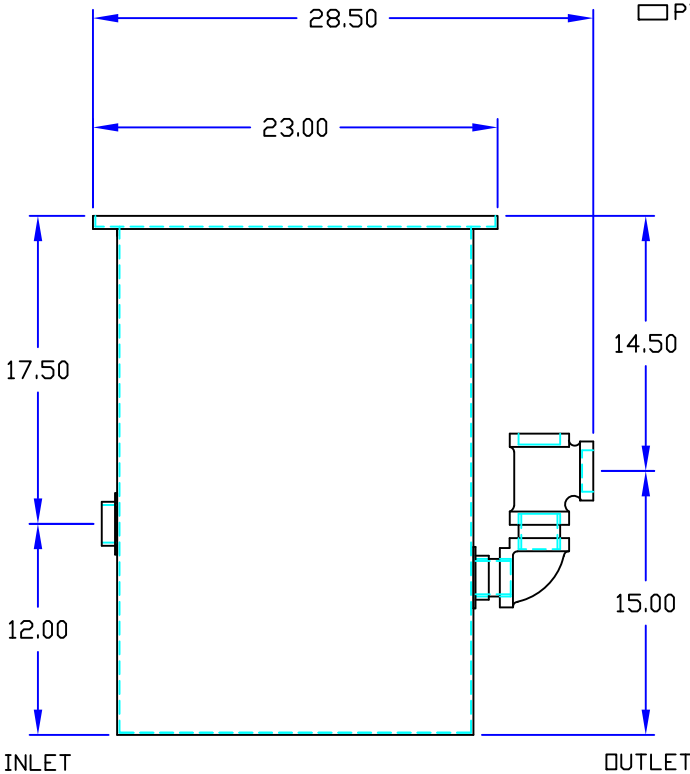

Specifications

Rockford Model GF-1820 all welded 10 Ga. steel separator, 17 gallon static capacity, 20 g.p.m. intermittent flow, 2.00" tapped inlet and outlet connection, 86 lbs. greasy sludge capacity, visible double-wall outside trap seal, easily removable filter screen removable 3/8" nonskid diamond tread-plate cover for flush in the floor installation suitable for pedestrian traffic secured with stainless flat head screws, heavy duty leak-proof gasket, PEX Shop Coat coating inside and bituminous coating outside.

Optional features (Additional cost) listed above

Approved By

Company

Date