



Rockford Sanitary Systems, Inc.

ROCKFORD, IL 61125-0963

(815) 229-5077 - (800) 747-5077 - FAX (815) 229-5108

WEB SITE-www.rkfdseparators.com E MAIL-rssem@rkfdseparators.com

MODEL NO. GF-1820-M

GREASE SEPARATOR

DRAWN BY

QUOTE #

JOB NAME

W.R.W.

INLET

OUTLET

8.50

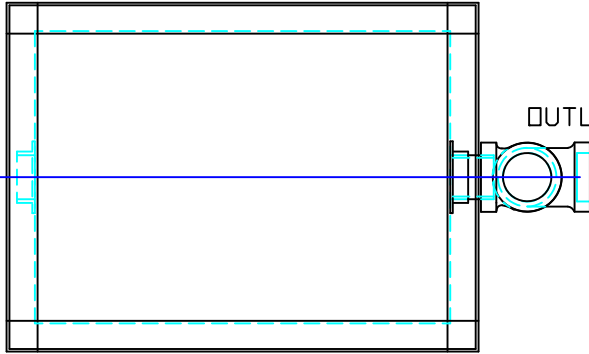

OPTIONAL FEATURES (ADDITIONAL COST)

- ANCHOR FLANGE
- RECESSED LIFT HANDLES IN COVERS
- EPOXY COATING
- REINFORCED COVER
- ALUMINUM COVER
- STAINLESS STEEL CONSTRUCTION
- SEDIMENT BASKET
- INTEGRAL EXTENSION _____ INCHES
- ALTERNATE VENT TAPPING SIZE _____ INCHES
- ALTERNATE INLET & OUTLET SIZE _____ INCHES
- CAST IRON OUTLET FITTINGS
- PVC OUTLET FITTINGS
- CLAMP RING
- ANODES
- FILTER MEDIA

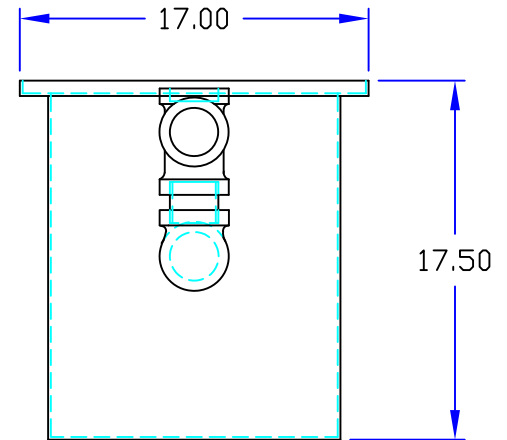
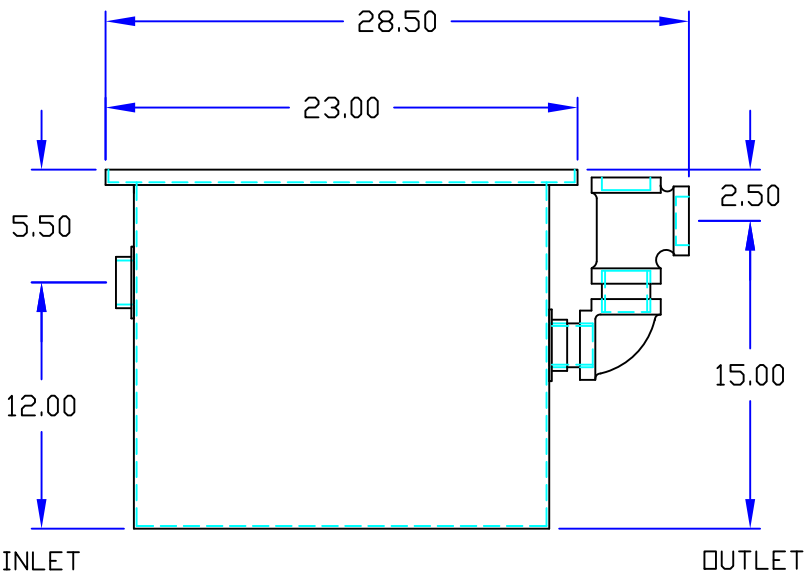

Specifications

Rockford Model GF-1820-M all 304 stainless separator, 17 gallon static capacity, 20 gpm intermittent flow, 2" threaded in/out, 86 lbs greasy sludge capacity, visible double wall outside trap seal, easily removable filter screen, .37" nonskid tread plate cover for flush with floor installation suitable for pedestrian traffic, secured with stainless screws, heavy duty gasket

Optional features (Additional cost) listed above

Approved By

Company

Date